

Mapping the transition state for ATP hydrolysis: implications for enzymatic catalysis

Suzanne J Admiraal and Daniel Herschlag*

B400 Beckman Center, Department of Biochemistry, Stanford University, Stanford, CA 94305-5307, USA

Background: Phosphoryl transfer, typically involving high energy phosphate donors such as ATP, is the most common class of biological reactions. Despite this, the transition state for phosphoryl transfer from ATP in solution has not been systematically investigated. Characterization of the transition state for the uncatalyzed hydrolysis of ATP would provide a starting point for dissection of enzyme-catalyzed reactions.

Results: We examined phosphoryl transfer from ATP, GTP and pyrophosphate to a series of alcohols; these reactions are analogous to the phosphorylation of sugars and other biological alcohols and to the hydrolysis of ATP. The Brønsted $\beta_{\text{nucleophile}}$ value of 0.07 is small, indicating that there is little bond formation between the incoming nucleophile and the electrophilic phosphoryl group in the transition state. Coordination of Mg^{2+} has no measurable

effect on this value. The Brønsted $\beta_{\text{leaving group}}$ value of -1.1 for phosphoryl transfer to water from a series of phosphoanhydrides is large and negative, suggesting that the bond between phosphorous and the leaving group oxygen is largely broken in the transition state.

Conclusions: Uncatalyzed hydrolysis of ATP in solution occurs via a dissociative, metaphosphate-like transition state, with little bond formation between nucleophile and ATP and substantial cleavage of the bond between the γ -phosphoryl moiety and the ADP leaving group. Bound Mg^{2+} does not perturb the dissociative nature of the transition state, contrary to proposals that enzyme-bound metal ions alter this structure. The simplest expectation for phosphoryl transfer at the active site of enzymes thus entails a dissociative transition state. These results provide a basis for analyzing catalytic mechanisms for phosphoryl transfer.

Chemistry & Biology November 1995, 2:729–739

Key words: ATP hydrolysis, GTP hydrolysis, linear free-energy relationship, phosphoryl transfer, transition-state structure

Introduction

The possible modes of conversion between the substrates and the products of a particular reaction may be represented by a free energy surface (Fig. 1). Substrates and products reside in energy wells on this surface, and the lowest energy course between these wells is traveled during the chemical transformation. The transition state corresponds to the entity of maximum energy along this path of least resistance, and it is the free energy of this transient species that dictates the rate of a reaction, according to transition-state theory [1]. An enzyme catalyzes a reaction by decreasing the energy of a transition state relative to reactants. An understanding of how enzymes achieve their enormous rate enhancements therefore begins with knowledge of the transition state for the uncatalyzed reaction.

The reaction of ATP with a nucleophile to produce ADP and a phosphorylated product is ubiquitous in biological chemistry (Fig. 2). Enzymes catalyzing this type of reaction include gradient-generating ATPases, energy-trafficking kinases and signal-transducing G proteins. The transition states for phosphoryl transfer reactions, of which ATP and GTP hydrolysis are examples, are typically assigned to a position along a continuum between dissociative and associative extremes (Fig. 3) [2–4]. The dissociative transition state has a small amount of bond formation to the incoming nucleophile, a large amount of bond cleavage to the outgoing

leaving group, and charge donation from the nonbridging phosphoryl oxygen atoms to phosphorus (Fig. 3a). In contrast, the associative transition state has a large amount of bond formation to the incoming nucleophile, a small amount of bond cleavage to the outgoing leaving group, and charge accumulation on the nonbridging phosphoryl oxygens (Fig. 3b). The catalytic strategies adopted by enzymes for stabilization of dissociative transition states may thus be different from those used to stabilize associative transition states.

The proposal that a dissociative, metaphosphate-like transition state exists for the reactions of phosphate monoesters, acyl phosphates and phosphorylated amines is supported by a substantial amount of data, including near-zero entropies and volumes of activation, a large bridge ^{18}O isotope effect, small Brønsted $\beta_{\text{nucleophile}}$ values and large negative values of $\beta_{\text{leaving group}}$ (for reviews see [2,3]). Phosphoanhydrides are analogous to phosphate monoesters in that they possess a single phosphoryl substituent, and it has been suggested that phosphoanhydrides also react via a dissociative transition state [5–10]. No systematic study of phosphoanhydride reactions has been performed, however. In light of the prevalence of these reactions in biology and the importance of the transition state for understanding catalysis, we have mapped the transition state for hydrolysis of ATP and related phosphoanhydrides. Linear free-energy relationships reveal a transition state with considerable dissociative character.

*Corresponding author.

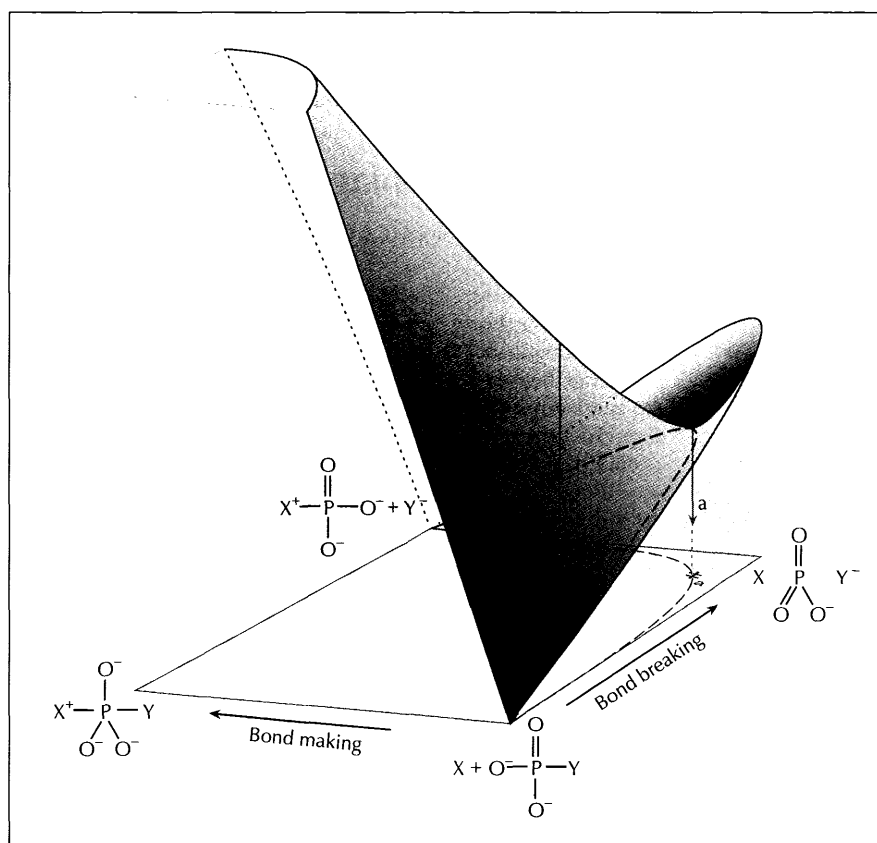

Fig. 1. Hypothetical free energy reaction surface for nonenzymatic phosphoryl transfer (after [78,79]). The axis horizontal to the plane of the page denotes bond-making between the nucleophile (X) and phosphorus, the perpendicular axis denotes bond-breaking between phosphorus and the leaving group (Y), and the vertical axis corresponds to free energy. Reactants are pictured in the lower right corner and products in the upper left corner. The upper right corner and lower left corner represent dissociative and associative extremes, respectively, for phosphoryl transfer. The dashed line is a hypothetical reaction coordinate for a reaction with dissociative character, and the transition state is labeled '‡'. The transition state is located at a free energy saddlepoint — the position of highest energy on the lowest energy reaction pathway. An enzyme could catalyze the reaction through stabilization of the transition state that is present in solution (arrow a), or it could change the transition state for reaction by providing more stabilization at a position of higher energy on the reaction surface (arrow b). Note that a transition state represents an average of extents of bonding for a population of reacting molecules.

Results and discussion

Linear free-energy relationships

The dissociative or associative nature of a phosphoryl transfer reaction is defined by the extent of bond formation between the incoming nucleophile and phosphorus and the extent of bond cleavage between phosphorus and the leaving group in the transition state (Fig. 3). The slopes of linear free-energy relationships correlating the pK_a values (proportional to a standard free energy change) of a series of nucleophiles or leaving groups with $\log k$ (a linear function of the free energy of activation, where k is the rate constant for reaction) are known as Brønsted, or β , values. These β values provide a measure of the bonding present in the transition state and are thus useful probes of transition-state structure (for reviews of linear free-energy relationships, see [1,11,12]). A small $\beta_{\text{nucleophile}}$, which is suggestive of little transition-state

bond formation between the nucleophile and phosphorus, together with a large and negative $\beta_{\text{leaving group}}$, which is suggestive of substantial transition-state bond cleavage between phosphorus and the leaving group, identify a phosphoryl transfer reaction as dissociative. The opposite trends (a large $\beta_{\text{nucleophile}}$ and a less negative $\beta_{\text{leaving group}}$) denote an associative transition state.

Nucleophilic involvement in the transition state

A series of primary alcohols of varying pK_a were used to investigate nucleophilic participation in the transition state for ATP hydrolysis. Two considerations determined the choice of nucleophiles: 1) although amine nucleophiles are more typically employed in Brønsted correlations of this sort, no reactions of amines with pyrophosphate were observed in preliminary experiments; and 2) the alcohols are chemical homologs of

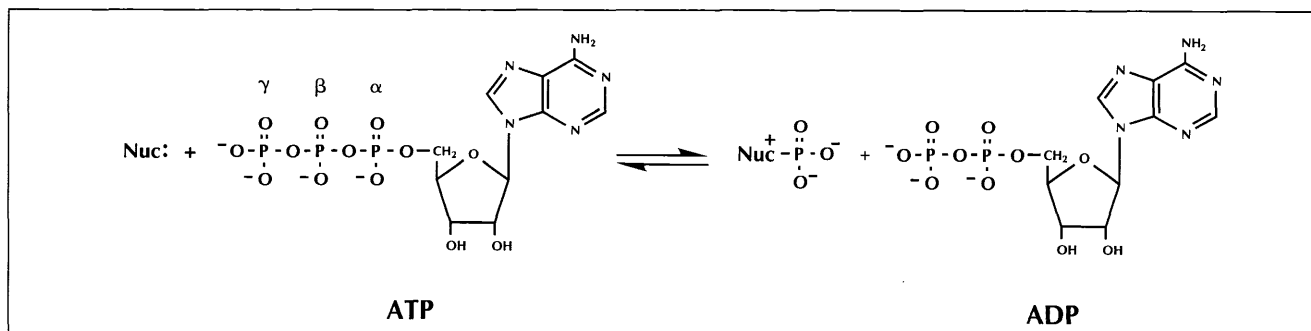

Fig. 2. Phosphoryl transfer from ATP to a nucleophile.

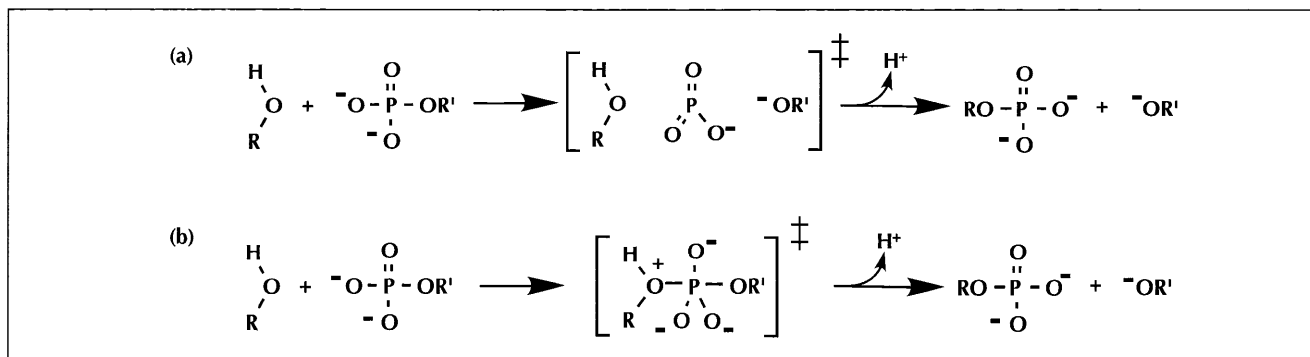

Fig. 3. Dissociative and associative extremes from the continuum of possible transition states for phosphoryl transfer. **(a)** The dissociative extreme is depicted by the single negative charge and two full double bonds to the nonbridging phosphoryl oxygens of the phosphoryl group being transferred (the actual nature of the bonding in metaphosphate and metaphosphate-like species is uncertain [80–82]), and by the absence of bonds to the incoming or outgoing groups. **(b)** The associative extreme is depicted by the three negative charges and single bonds to the nonbridging phosphoryl oxygens of the phosphoryl group being transferred, and by the bonds to the incoming and outgoing groups. A dissociative transition state (\ddagger , a) has a decrease in the combined bond order to incoming and departing groups relative to reactant, whereas an associative transition state (\ddagger , b) has an increase in the combined bond order. ‘Phosphoryl transfer’ generally refers to transfer of $-\text{PO}_3^{2-}$, $-\text{P}(\text{OR})\text{O}_2^-$, or $-\text{P}(\text{OR})_2\text{O}$ moieties. This paper addresses reactions of monosubstituted phosphoryl groups for which $-\text{PO}_3^{2-}$ is transferred. For simplicity, the term phosphoryl transfer is used to describe this subclass of reactions when specific reactions are referred to in the text.

biological nucleophiles such as sugars, water and the serine and threonine residues phosphorylated by protein kinases.

A complication of using alcohols as nucleophiles in aqueous solution, however, is that high concentrations of the alcohol must be present for it to compete with water. This introduces changes in solvent composition. For this reason, the partitioning between reaction with the alcohol and reaction with water was followed, allowing determination of the rate constant k_{rel} for reaction of the alcohol relative to that for reaction with water (Fig. 4). Effects on reactivity from changes in bulk solvent upon addition of the alcohols are predicted to have the same effect on both the alcohol and water reactions, to a first approximation, and thus not greatly influence the value of k_{rel} . This expectation was confirmed by the observation that k_{rel} was the same regardless of the alcohol concentration in the reaction mixture (10–50 %, v/v; see Materials and methods).

The reaction of ATP^{4-} in aqueous alcohol gave fractional yields of alkyl phosphate, relative to total product, of 0.04, 0.07, 0.18, 0.07, 0.11, 0.09, 0.10 and 0.02 in 30 % (v/v) n-propanol, ethanol, methanol, methoxyethanol, fluoroethanol, hydroxypropionitrile, propargyl alcohol and trifluoroethanol, respectively. The relative rate constants in Table 1 were calculated from these fractions of alkyl phosphate and the molar concentrations of alcohol and water present, according to the equation in Figure 4. A plot of alcohol $\text{p}K_{\text{a}}$ versus $\log k_{\text{rel}}$ gives a slope of $\beta_{\text{nucleophile}} = 0.07 \pm 0.08$ (Fig. 5, open symbols). Thus, the reaction behaves as if ~ 0.07 of a positive charge has developed on the nucleophilic oxygen atom in the transition state, suggesting that a minimal amount of nucleophilic attack has occurred by the time the transition state is reached. Analogous experiments yielded $\beta_{\text{nucleophile}} = 0.05 \pm 0.08$ for solvolysis of GTP^{4-} and $\beta_{\text{nucleophile}} = 0.06 \pm 0.06$ for solvolysis of pyrophosphate dianion.

This small dependence of relative rate on nucleophilicity for ATP, GTP and pyrophosphate lends support to the idea that the transition state is dissociative, and is similar to results obtained with phosphate monoesters and acyl phosphates. For example, $\beta_{\text{nucleophile}} = 0, 0.13, \text{ and } 0.14$ for the reaction of 2,4-dinitrophenyl phosphate dianion with a series of pyridines, reaction of *p*-nitrophenyl phosphate dianion with amine nucleophiles, and solvolysis of acetyl phosphate dianion, respectively [13–15].

It has been suggested that bound metal ions on enzymes may convert the otherwise dissociative phosphoryl transfer into a more associative process by withdrawing negative charge from the reactive phosphorus and promoting nucleophilic attack (see Fig. 6) [14,16–22]. To test the hypothesis that a metal may alter the transition state for reaction of a phosphoanhydride, $\beta_{\text{nucleophile}}$ was determined for solvolysis of ATP^{4-} with bound Mg^{2+} . Values of k_{rel} were determined for the $\text{ATP} \cdot \text{Mg}$ complex (Table 1) and are essentially identical to those determined for ATP alone. These values give $\beta_{\text{nucleophile}} = 0.06 \pm 0.07$ (Fig. 5, closed symbols), which is the same, within experimental error, as the $\beta_{\text{nucleophile}}$ of 0.07 ± 0.08 obtained in the absence of Mg^{2+} . These results provide no indication

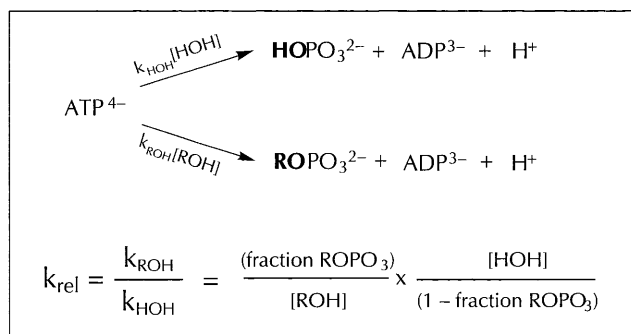

Fig. 4. Partitioning of phosphoryl transfer between water and alcohol.

Table 1. Rate constants for solvolysis of ATP⁴⁻ and ATP⁴⁻•Mg²⁺ ^a.

ROH	pK _{ROH} ^c	ATP ⁴⁻		ATP ⁴⁻ •Mg ²⁺ ^b	
		10 ⁵ x k _{obs} , min ⁻¹	k _{rel}	10 ⁵ x k _{obs} ^{Mg} , min ⁻¹	k _{rel} ^{Mg}
HOH	15.7	4.2	(1)	13	(1)
CH ₃ CH ₂ CH ₂ OH	16.1 ^d	7.5	0.39 ± 0.09	20	0.48 ± 0.06
CH ₃ CH ₂ OH	16.0	6.0	0.59 ± 0.13	18	0.45 ± 0.13
CH ₃ OH	15.5	7.1	1.12 ± 0.12	20	1.33 ± 0.12
CH ₃ OCH ₂ CH ₂ OH	14.8	8.5	0.76 ± 0.16	26	0.86 ± 0.12
CFH ₂ CH ₂ OH	14.3 ^e	6.7	0.96 ± 0.33	24	0.81 ± 0.06
N≡CCH ₂ CH ₂ OH	14.0	6.6	0.83 ± 0.29	21	0.77 ± 0.08
HC≡CCH ₂ OH	13.6	5.6	0.88 ± 0.09	22	0.80 ± 0.20
CF ₃ CH ₂ OH	12.4	6.1	0.19 ± 0.04	19	0.24 ± 0.04

^a60 °C, 30 % ROH, I = 0.1 [NaCl or (CH₃)₄NCl]. The identity of the salt used to maintain constant ionic strength had no effect on k_{obs}, k_{rel}, k_{obs}^{Mg}, or k_{rel}^{Mg} and varying the percent ROH from 10–50 % had only ~2-fold effects on k_{obs} and k_{obs}^{Mg} and no significant effect on k_{rel} or k_{rel}^{Mg}. Errors represent one standard deviation from an average of at least three determinations of k_{rel} or k_{rel}^{Mg}.

^b[MgCl₂] = 5 mM; Mg²⁺ is saturating at this concentration [73,74]. No change in k_{rel}^{Mg} was observed from 0.1–10 mM Mg²⁺, though there is a small increase in k_{obs}, presumably an effect from a second Mg²⁺.

^cFrom [75] unless otherwise noted.

^dFrom [76].

^eTrifluoroethanol and trichloroethanol differ in pK_a by only 0.2 units (12.4 vs 12.2 [75]). The pK_a of fluoroethanol was assumed to be identical to the pK_a of chloroethanol because a single halogen substituent is expected to have less of an effect on pK_a than three halogen substituents. A different value of pK_a for fluoroethanol would have a negligible effect on β_{nucleophile}, because k_{rel} is largely independent of pK_a.

that the metal ion alters the transition state for ATP hydrolysis. Likewise, no significant change in transition-state structure was observed upon coordination of Mg²⁺ or Ca²⁺ to *p*-nitrophenyl phosphate, a phosphate monoester ([23]; see also [24]).

Further support for minimal perturbation of ATP by bound metal is derived from a secondary ¹⁸O equilibrium

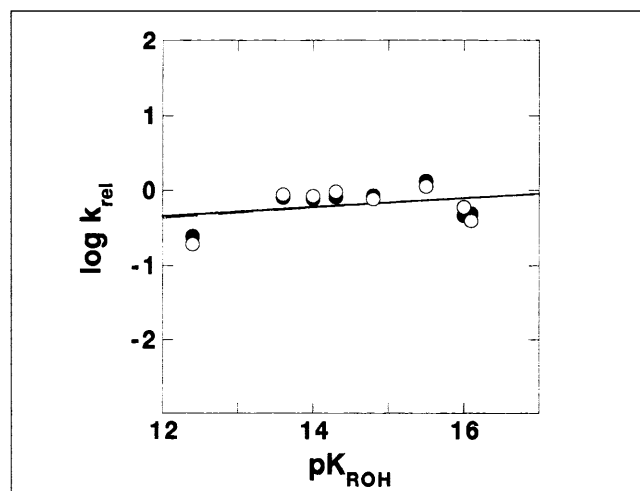

Fig. 5. Dependence of the rate constants for the reactions of primary alcohols with ATP⁴⁻ (○) or ATP⁴⁻•Mg²⁺ (●) on the pK_a of the alcohol. The data are from Table 1. Lines are least-squares fits to the data and give slopes of β_{nucleophile} = 0.07 for reactions of ATP⁴⁻ and β_{nucleophile} = 0.06 for reactions of ATP⁴⁻•Mg²⁺; the lines are essentially superimposable.

isotope effect for Mg²⁺ coordination that is negligible compared to the isotope effect for protonation [25]. Similarly, the increase in the symmetric P–O stretching vibrational frequency of the γ-phosphoryl group of ATP upon coordination of Mg²⁺ is only ~1/20 of the increase upon protonation [26]. The absence of an effect of Mg²⁺ coordination on β_{equilibrium} for formation of phosphorylated pyridines also suggests that the metal ion-promoted perturbation is small relative to that of a proton [24]. While the use of metal ions in biological catalysis may have been favored by the higher concentrations of metal ions than protons *in vivo*, it appears that the effects from ionic interactions with metal ions are often less than those from covalent interactions with protons.

Extent of bonding to the leaving group in the transition state

The hydrolysis of a series of phosphoanhydrides was investigated to determine the effect of the leaving group on reactivity (Table 2). A Brønsted plot (Fig. 7) gives

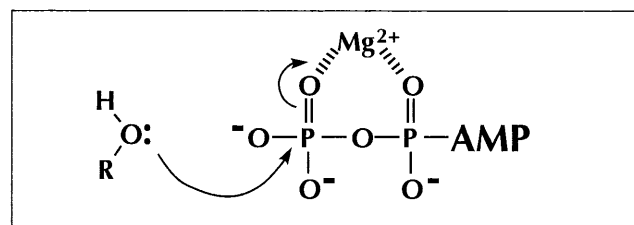
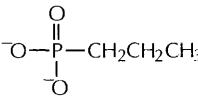
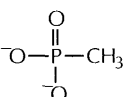
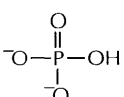
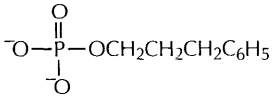
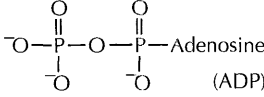
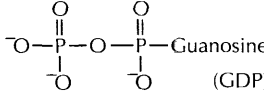
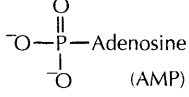
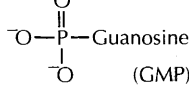
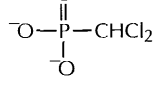
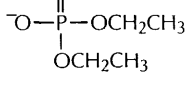

Fig. 6. Schematic representation of the proposal made in the literature [14,16–22] that metal coordination might convert phosphoryl transfer from a dissociative to an associative process.

Table 2. Hydrolysis of a series of phosphoanhydrides and related compounds^a.

Leaving group	pK _{leaving group} ^b	k _{hydrolysis} min ⁻¹ × 10 ⁵
	7.8 ^c	1.2
	7.5 ^c	1.3
	6.7	40
	6.7 ^d	30 ^e
	6.4	240
	6.4	290
	6.3	99
	6.3	75
	5.2 ^c	600
	1.4 ^f	880 000 ^g

^a95 °C, I = 0.1.^bFrom [77] unless otherwise noted; 25 °C, I = 0.2.^cMeasured at 23 °C, I = 0.2.^dEstimated based on a pK_a of 6.7 for propyl phosphate [75].^eFrom [6].^fFrom [75].^gFrom [7].

$\beta_{\text{leaving group}} = -1.1 \pm 0.2$, indicating that a large amount of negative charge has developed on the leaving group in the transition state. This charge acquisition suggests that the bond between phosphorus and the leaving group is nearly broken in the transition state, reinforcing the arguments for a dissociative transition state. Once again, this outcome is in agreement with prior results from studies of other monosubstituted phosphoryl compounds: $\beta_{\text{leaving group}} = -1.2$ for hydrolysis of aryl and benzoyl phosphates [27,28], and $\beta_{\text{leaving group}} = -(1.0-0.9)$ for reaction of aryl phosphates with amine nucleophiles [13].

Transition-state structure for nonenzymatic and enzymatic phosphoryl transfer

The large amount of bond cleavage between phosphorus and the leaving group in combination with little bond formation between phosphorus and the nucleophile provide strong evidence in favor of a dissociative transition state for nonenzymatic reactions of ATP (Fig. 8). But do enzymes catalyze phosphoryl transfer reactions by stabilizing this transition state (Fig. 1, arrow a), or do they perturb the energy surface for reaction in a way that alters the nature of its transition state (Fig. 1, arrow b)?

The simplest expectation for reaction of ATP and other phosphoryl donors at the active site of an enzyme is that the transition state follows the dissociative, metaphosphate-like transition state observed in solution, as this would require the least amount of stabilization to achieve a given rate enhancement. Several lines of evidence

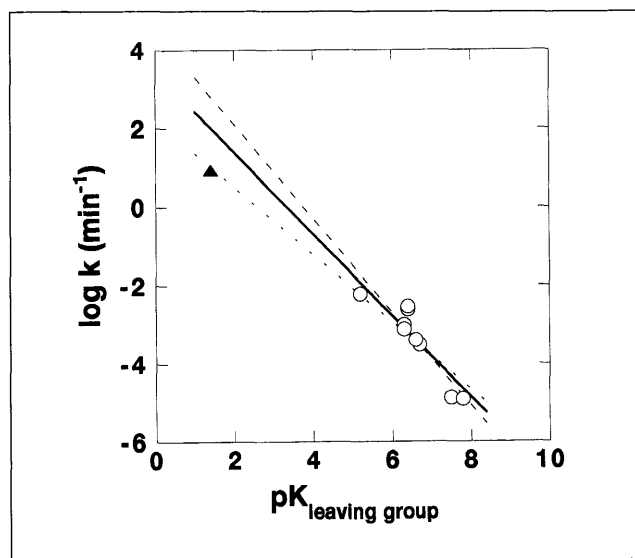

Fig. 7. Dependence of the hydrolysis of phosphoanhydrides on leaving group pK_a. Data are from Table 2. The upper dashed line of slope -1.2 is a least-squares fit to the circles (○), representing reactions involving leaving groups of the type: -OP(O)₂Y. The closed triangle (▲) corresponds to the reaction in which diethylphosphate [-OP(O)(OR)₂] is the leaving group [7]; its inclusion in a least-squares fit gives the lower dashed line of slope -0.9. The slopes of these lines are taken to be outer limits for $\beta_{\text{leaving group}}$, and their average is represented by the solid line of slope $\beta_{\text{leaving group}} = -1.1$. The conclusions drawn in the text do not change depending on which of these slopes is used to represent $\beta_{\text{leaving group}}$.

suggest that a dissociative transition state is indeed maintained for enzymatic phosphoryl transfer, although this has not been proven. Investigations of nonenzymatic phosphoryl transfer indicate that the energy surface in the vicinity of the transition state for these reactions is steep, making the transition state difficult to change [23,24,29]. For example, increasing the nucleophilicity by 10^{18} -fold via a change in nucleophile from water to hydroxide ion increases the extent of bonding in the transition state for phosphoryl transfer from a phosphorylated pyridine by only ~ 0.2 of a bond, as determined from linear free-energy relationships [24]. Furthermore, in a recent study of *Escherichia coli* alkaline phosphatase, which catalyzes phosphoryl transfer from phosphate monoesters, a large dependence of rate on leaving group $\text{p}K_{\text{a}}$ was measured ($\beta_{\text{leaving group}} = -0.8$ for $k_{\text{cat}}/K_{\text{M}}$ for a series of substituted phenyl phosphorothioate substrates), suggestive of a large amount of bond cleavage in a dissociative transition state [30]. Similarly, primary and secondary ^{18}O isotope effects for bridging and nonbridging phosphoryl oxygens, respectively, suggest that the protein tyrosine phosphatases from *Yersinia* and rat react via a dissociative transition state (A.C. Hengge, G. Sowa, L. Wu & Z.-Y. Zhang, personal communication). Finally, inverse secondary ^{18}O isotope effects for the nonbridging phosphoryl oxygen atoms for phosphoryl transfer by alkaline phosphatase and hexokinase are consistent with a dissociative transition state for these enzymatic reactions [25,31].

A dissociative transition state is also expected for enzymatic phosphorylation and dephosphorylation of histidine, because the transition state structures and energy surface curvatures are indistinguishable for nonenzymatic reactions of oxygen and nitrogen nucleophiles [24].

Implications of a dissociative transition state for enzymatic catalysis

Despite extensive nonenzymatic evidence and the enzymatic examples cited above in support of a dissociative transition state, most literature discussions of enzymatic phosphoryl transfer have explicitly or implicitly assumed an associative transition state. This may have arisen in part from a perception that stabilization of a dissociative transition state would constitute a difficult task for the enzyme [32].

How could an enzyme catalyze phosphoryl transfer via a dissociative transition state? Figure 8b summarizes the electrostatic differences between the ground state and the transition state for phosphoryl transfer from ATP. This picture of the nonenzymatic reaction of ATP is used in the following discussion to evaluate previous catalytic proposals and to highlight features that may enable enzymes to stabilize a dissociative transition state selectively.

(1) The nucleophile is little changed between ground state and transition state

Enzymatic residues and the phosphoanhydride substrate itself have been suggested to be general base catalysts that activate the attacking nucleophile (see, for example,

[33–45]). There is little nucleophilic participation in a dissociative transition state, however (Fig. 8), so increased nucleophilicity is not expected to confer a large rate advantage. Though a general base may not provide much stabilization of the transition state for phosphoryl transfer, it may be required to deprotonate the product in an active site with restricted solvent access [24,46]. Aspects of general base catalysis are discussed in more depth for the specific example of Ras-catalyzed GTP hydrolysis (K.A. Maegley, S.J.A. and D.H., unpublished data).

(2) The nonbridging γ -phosphoryl oxygens show a decrease in electron density

Positively-charged amino acids and enzyme-bound metal ions are often suggested to have the catalytic function of stabilizing the development of negative charge on the γ -phosphoryl oxygens of NTPs (see, for example, [33,34,42,43,47–53]). Although such electrostatic interactions would stabilize an associative transition state, in which there is an increase in charge on the nonbridging γ -phosphoryl oxygens (Fig. 3b), they would not catalyze a reaction with a dissociative transition state. Indeed, if the γ -phosphoryl oxygens experience a loss of negative charge in the transition state, as predicted for the observed dissociative reaction (Fig. 3a), then these interactions would be anti-catalytic.

Nevertheless, active sites of phosphoryl transfer enzymes are replete with positively charged residues and metal ions. If these moieties are not stabilizing negative charge development in an associative transition state, what is their role? These positively charged groups could position the substrate with respect to the nucleophile and with respect to residues whose electrostatic interactions with the substrate are strengthened in the transition state. It is also possible that an enzyme uses positively charged residues and metal ions in the vicinity of the phosphoryl oxygens to preferentially recognize the trigonal bipyramidal shape of the transition state relative to the tetrahedral ground state, selectively stabilizing the transition state to provide catalysis. However, we are aware of no data suggesting that enzymes have sufficient rigidity to allow such discrimination on the basis of geometry [54].

(3) The β - γ bridging oxygen undergoes the largest charge increase

The β - γ bridging oxygen develops a charge of -0.55 during progression from ground state to transition state, the largest charge change of any of the atoms participating in the reaction (Fig. 8). Consequently, it would seem to be a prime candidate for stabilization by metal ions or hydrogen bond donors, yet it is rarely mentioned in catalytic proposals. The catalytic potential of such interactions may be even greater due to substrate destabilization [55–57]. Recognition of this possibility has led to a new proposal for catalysis of GTP hydrolysis by Ras and its activation by GAP (K.A. Maegley, S.J.A. and D.H., unpublished data), and analogous mechanisms may generally be employed in catalysis of phosphoryl transfer.

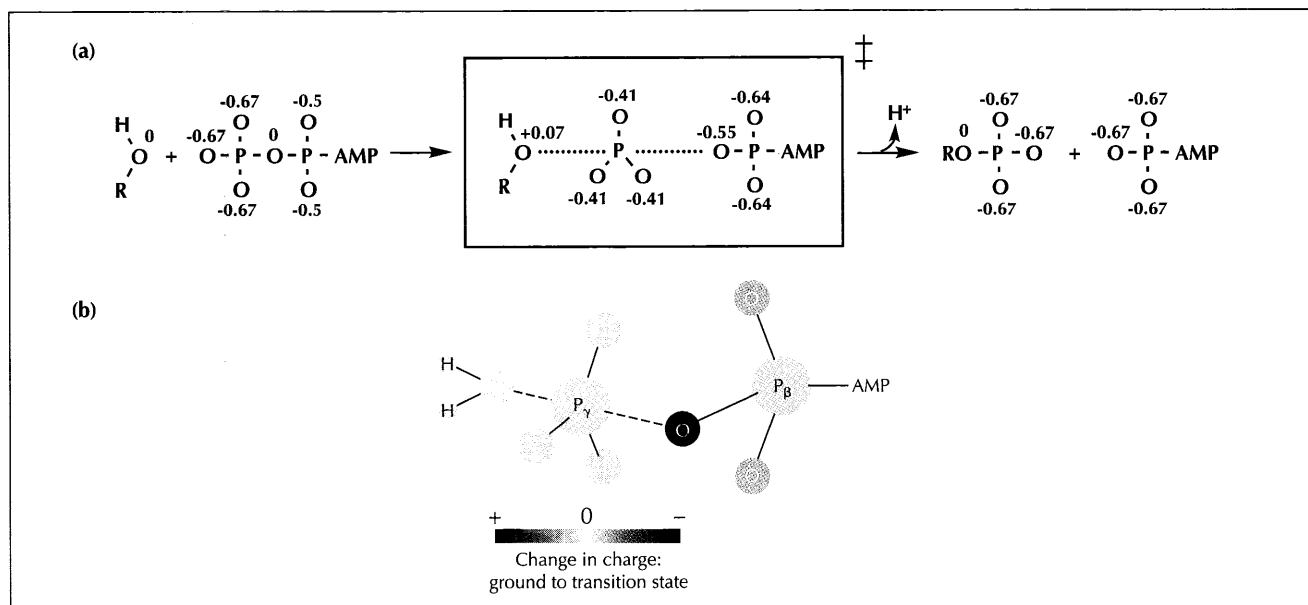

Fig. 8. Transition-state charge estimates for the uncatalyzed hydrolysis of ATP. (a) Charges on oxygens of the reactants, transition state and products for ATP hydrolysis estimated from linear free energy relationships (see Materials and methods). (b) A schematic representation of the change in charge in going from the ground state to the transition state from part (a). The transition-state geometry is depicted, with the phosphoryl group undergoing transfer separated from the water nucleophile and the ADP leaving group by dashed lines. All of the charge changes are shown localized to the oxygen atoms.

(4) *There is modest charge development on the β -phosphoryl nonbridging oxygen atoms*

Although the increase in negative charge on each β -nonbridging oxygen atom in the transition state, estimated to be -0.14 , is considerably smaller than the increase on the β - γ bridging oxygen (Fig. 8), strengthened electrostatic and hydrogen-bonding interactions with the β -nonbridging oxygens could stabilize a dissociative transition state. Enzymes appear to catalyze reactions through multiple interactions that each provide a modest amount of transition-state stabilization [57–59].

An overall inspection of Figure 8b suggests two additional catalytic strategies. First, fixing the nucleophile with respect to the γ -phosphoryl group at an active site can lower the entropic barrier for reaction, as observed in model phosphoryl transfer reactions [46]. Second, the change in charge in going from the ground state to the transition state has dipolar character, with the groups on one side of the transferred phosphoryl group becoming more positive and those on the other side more negative (Fig. 8b, colored red and blue, respectively). This overall charge redistribution could be stabilized by enzymatic dipoles.

The effect of metal ions on nonenzymatic reactions of phosphoanhydrides can also be related to Figure 8b. There is little effect of coordination by Mg^{2+} or other divalent metal ions on the rate of ATP hydrolysis (Table 1; see also [60–64]). In addition, the rates of hydrolysis of various metal ion complexes of μ -monothiopyrophosphate (pyrophosphate with the bridging oxygen atom substituted by sulfur) are essentially independent of the thiophilicity of the metal ions [65]. These small rate effects

may result from an absence of interactions between the metal ions and the bridging atom, the atom that undergoes the largest change in charge in going from the ground state to the transition state (Fig. 8b; see (3), above). A further rationale for the small effects is that transition-state stabilization from metal ion interactions with the β -phosphoryl nonbridging oxygens of ATP may be offset by weakened transition-state interactions with the γ -phosphoryl oxygens (see (2) and (4) above, and [23]).

Significance

The transition state for the uncatalyzed reaction provides a starting point for enzymatic analysis because it is this entity that an enzyme must stabilize or modify for catalysis to occur. We find that reactions of ATP proceed via a dissociative transition state. Thus, this dissociative transition state serves as a reference for discussion of the catalytic mechanisms of enzymes that transfer the terminal phosphoryl moiety from a phosphoanhydride to an acceptor. It will be interesting to discover whether enzymes stabilize transition states that are closely related to the transition states of the corresponding uncatalyzed reactions, as the limited data to date suggest, or whether some enzymes change the nature of the transition state.

Analysis of the change in charge distribution during progression from ground state to dissociative transition state calls into question the catalytic potential of some previously proposed mechanisms for phosphoryl transfer. The analysis also highlights the β - γ bridging oxygen as the atom

experiencing the largest charge development in the transition state. This suggests that phosphoryl transfer enzymes may in general make catalytic interactions with the bridging oxygen, an idea that leads to specific mechanistic proposals.

Materials and methods

Materials

Ethanol, 2-fluoroethanol, 3-hydroxypropionitrile, methanol, 2-methoxyethanol, 1-propanol, propargyl alcohol and 2,2,2-trifluoroethanol were from Aldrich and were the highest purity available ($\geq 99\%$, with the exception of 2-fluoroethanol, 95%). Methylphosphonic acid and propylphosphonic acid were obtained from Aldrich, monopotassium ADP and dilithium GDP from Boehringer Mannheim, triethylammonium [γ - ^{32}P]ATP and [γ - ^{32}P]GTP from Amersham; sodium [^{32}P]pyrophosphate was obtained from DuPont NEN and dichloromethylphosphonic dichloride from Johnson Matthey. Water was doubly distilled from an all-glass apparatus.

Synthesis

Dichloromethylphosphonic acid was prepared by addition of the dichloride to an excess of water. Phosphonic acids were converted to their corresponding phosphoryl phosphonates via the reaction of the phosphonomorpholides with tri-*n*-butylammonium phosphate, as described by Moffatt and Khorana [66] for phosphorylation of ribonucleoside phosphates. The resulting lithium salts of the phosphoryl phosphonates were separated from phosphonate starting material by anion-exchange chromatography (Mono Q HR 5/5, Pharmacia) with a NaCl gradient, and the phosphoryl phosphonates were isolated as triethylammonium salts following anion exchange on Toyopearl DEAE-650C resin prior to use in reactions. Structures were confirmed by ^1H NMR, ^{31}P NMR, and liquid secondary-ion mass spectrometry. Two ^{31}P -NMR signals were observed for each phosphoryl phosphonate, as expected (161.9 MHz, parts per million (ppm) downfield from 85% H_3PO_4 ; $\delta_{\text{p}} = 3.6, -6.6$, $J_{\text{pp}} = 24$ Hz for phosphoryl dichloromethylphosphonate; $\delta_{\text{p}} = 23.0, -8.0$, $J_{\text{pp}} = 23$ Hz, $J_{\text{pH}} = 18$ Hz for phosphoryl methylphosphonate; $\delta_{\text{p}} = 26.0, -8.0$, $J_{\text{pp}} = 25$ Hz, $J_{\text{pH}} = 18$ Hz for phosphoryl propylphosphonate). Peaks identified as phosphonate starting material and inorganic phosphate and amounting to $\sim 5\%$ of the total product were also observed in the final preparations; this contamination was probably due to a small amount of phosphoryl phosphonate hydrolysis during processing and was shown not to affect the results obtained (see below).

Determination of $\beta_{\text{nucleophile}}$

Reactions of pyrophosphate, ATP and GTP in alcohol/water mixtures were performed at 60 °C in buffered solutions of ionic strength 0.4 M [$(\text{CH}_3)_4\text{NCl}$] for pyrophosphate, or ionic strength 0.1 M [NaCl or $(\text{CH}_3)_4\text{NCl}$] in the presence of 0.1 mM ethylenediaminetetraacetic acid (EDTA) for ATP and GTP. The ATP and GTP reactions were also performed with 0.1–10 mM MgCl_2 . Reaction mixtures contained 10 μM carrier ATP or GTP spiked with [γ - ^{32}P]ATP or [γ - ^{32}P]GTP, or 500 μM pyrophosphate spiked with [^{32}P]pyrophosphate to give $\sim 10^4$ counts per minute (cpm) per μl . A 10-fold increase in the concentration of starting material had no effect on the observed absolute or relative rate constants, indicating that these reactions are independent of phosphoanhydride concentration. ^{31}P -NMR chemical shifts and proton-phosphorus coupling constants consistent with the expected products,

inorganic phosphate and alkyl phosphate, were observed for analogous nonradioactive reactions. To determine absolute and relative rates, reaction aliquots were quenched at 0 °C at specific times, substrates and products were separated by thin layer chromatography (TLC) (using polyethyleneimine (PEI) cellulose; 1 M LiCl, 0.3 M sodium phosphate, pH 3.8 or 1 M LiCl, 50 mM sodium N-[2-acetamido]-2-iminodiacetic acid (NaADA), pH 6.3), and their ratios were quantitated by phosphorimager analysis (Molecular Dynamics). The ratio of alkyl phosphate to inorganic phosphate produced in alcohol/water mixtures was constant throughout the time course, indicating that no secondary reactions involving the reaction products were occurring. Faster reactions of GTP, ATP and pyrophosphate were shown to proceed to completion, so a substrate endpoint of zero was assumed for slow reactions that were not followed to completion. Pseudo-first-order rate constants (k_{obsd}) were obtained from nonlinear least-square fits (Kaleidagraph, Abelbeck Software) to an exponential curve. Fits were excellent ($r > 0.99$) in all cases. Relative rate constants were determined from the fraction of total product present as alkyl phosphate in aqueous alcohol solutions, according to the equation in Figure 4.

There was no change in k_{rel} for each alcohol over a range of 10–50 % alcohol (50–28 M [HOH]), indicating that solvent effects from the alcohol present in the reaction mixtures did not affect the observed values of k_{rel} . (In principle, each k_{rel} value can be extrapolated to 0 % alcohol so that the values all correspond to reactions in the same solvent, water. The extrapolation is unnecessary in this case, however, because varying the alcohol percentage did not affect k_{rel} for reaction of ATP in a particular alcohol.) The following considerations also suggest that the added alcohol does not alter the properties of the reaction; 1) there was no significant change in k_{HOH} for reaction of ATP, GTP or pyrophosphate as each alcohol was varied over the range of 10–50 %, nor was there a large difference (< 2 -fold) in k_{HOH} observed in the presence of the different alcohols; 2) apparent pK_a 's for the dianion to trianion and trianion to tetraanion of pyrophosphate were within 0.5 pH units in water and the alcohol/water mixtures (titrations performed at 0, 20 and 50 % alcohol for ethanol and trifluoroethanol).

Solvolysis was followed at three different pH values (pH values at 25 °C: pH 7.5 in 50 mM sodium N-[2-hydroxyethyl]piperazine-*N'*-[2-ethanesulfonic acid] (NaHEPES), and pH 9.1 or 10.0 in 50 mM sodium 2-[N-cyclohexylamino]ethanesulfonic acid (NaCHES)) for the NTPs to ensure that reaction of the appropriate ionic form was observed. Rates at pH 7.5 were within three-fold of those at pH 9.1 and rates were the same (within 10 %) at pH 9.1 and pH 10.0, indicating that solvolyses of the NTP tetraanions were followed at the higher pH values. Similarly, solvolysis of pyrophosphate was followed at several pH values (pH values at 25 °C: pH 1 and 2 in 0.1 M or 0.01 M nitric acid, respectively; pH 4.1 in 0.1 M sodium formate; pH 5.2 in 0.1 M sodium acetate; pH 6.9 in 0.1 M sodium 3-[N-morpholino]propanesulfonic acid (NaMOPS); pH 7.9 in 0.1 M sodium N-[2-hydroxyethyl]piperazine-*N'*-[3-propanesulfonic acid] (NaEPPS); and pH 9.0 or 10.2 in 0.1 M NaCHES) to identify the pH regime corresponding to the dianionic species. In agreement with previous work [67–69], a rate plateau for the dianion of pyrophosphate was observed between approximately pH 3 and pH 5.5. This rate plateau was also observed for solvolysis in alcohol/water mixtures, so reactions were monitored within this range. The observation

of the methyl phosphate product by both TLC and ^{31}P NMR contradicts the previous conclusion that there is no reaction between pyrophosphate and methanol [5]. The earlier work relied on an indirect assay of the decrease in the final amount of inorganic phosphate product.

Determination of $\beta_{\text{leaving group}}$

Hydrolyses of phosphoanhydrides and related compounds were performed at 95°C in buffered solutions of ionic strength 0.1 M (NaCl) in the presence of 0.1 mM EDTA. Reaction aliquots were quenched at 0°C, and the amount of inorganic phosphate product was determined colorimetrically [70] for reactions containing phosphoryl dichloromethylphosphonate, phosphoryl methylphosphonate, phosphoryl propylphosphonate, ADP, or GDP, and by the TLC assay outlined above for reactions containing $[\gamma\text{-}^{32}\text{P}]\text{ATP}$, $[\gamma\text{-}^{32}\text{P}]\text{GTP}$, or $[\text{}^{32}\text{P}]\text{pyrophosphate}$. Endpoints were determined by effecting complete hydrolysis of each sample in 0.5 N HCl. Reactions exhibited first-order behavior, and first-order rate constants were obtained from nonlinear least square fits (Kaleidagraph, Abelbeck Software) to an exponential curve. Fits were good ($r > 0.98$) in all cases. The reactions were monitored at several pH values (pH measured at 25°C: pH 9.1 or 10.0 in 50 mM NaCHES; pH 10.9 in 50 mM sodium 3-[cyclohexylamino]-1-propanesulfonic acid (NaCAPS); pH 12.6, 13.0 and 13.5 in 0.04, 0.1 and 0.3 N NaOH, respectively) to identify the pH-independent rate for the ionic species that gives transfer of PO_3^{2-} for each substrate (i.e., ADP^{3-} , ATP^{4-}). The presence of small amounts of phosphonate and inorganic phosphate in the three phosphoryl phosphonate substrates (see Synthesis above) did not influence the results, as demonstrated by the absence of a rate effect when these species were directly added to control reactions.

Estimation of charges

The slope of a linear free-energy relationship plotting the log of an equilibrium constant, K_{eq} , against $\text{p}K_{\text{a}}$ for a series of related compounds is $\beta_{\text{equilibrium}}$; it provides a measure of the change in 'effective charge' in going from substrate to product relative to a change in charge for the deprotonation equilibrium [2,71]. In the case of phosphoryl transfer, a $\beta_{\text{equilibrium}}$ of -1.35 for the equilibrium:

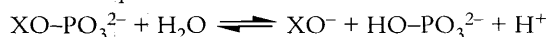

estimates an effective charge for the bridging oxygen of a phosphate monoester (XO-PO_3^{2-}) as $+0.35$ relative to XO-H [72]. The value of $\beta_{\text{equilibrium}} = -1.1$ for the hydrolysis of phosphoanhydrides and related compounds (see Results and discussion) supplies the effective charge which develops on the leaving group in the transition state. This value estimates that $-1.1/-1.35 = 0.81$ of the total charge change associated with the leaving group has occurred in the transition state. Knowledge of the charge on a leaving group oxygen before and after the reaction then enables estimation of its transition state charge by adding 0.81 of the total charge change on that atom to the charge present on that atom in the reactant. For example, the charge on the bridging oxygen changes from 0 in the reactant to -0.67 in the product; $0.81 \times -0.67 = -0.55$, so this charge is assigned to the bridging oxygen in the transition state. Similarly, charges of -0.64 are assigned to the nonbridging oxygens of the leaving group in the transition state. The $\beta_{\text{nucleophile}}$ of 0.07 (see Results and discussion) places an approximate charge of $+0.07$ on the nucleophile in the transition state. The total leaving group charge of -1.83 , the nucleophile charge of $+0.07$, and the need to conserve an overall transition state charge of -3 , then give a charge estimate of

-1.24 for the phosphoryl group being transferred. This charge is assumed to be equally distributed among the oxygens of the metaphosphate-like transition structure, so the charge on a phosphoryl oxygen is estimated to be -0.41 in the transition state. These numerical estimates are presented to aid the qualitative analysis of potential catalytic mechanisms in the Results and discussion.

Acknowledgements: We thank the Mass Spectrometry Facility, University of California, San Francisco for mass spectrometry analysis, Jasenka Adamic and G. Michael Blackburn for advice on synthesis, and Alvan Hengge and Zhong-Yin Zheng for communication of results prior to publication. We are grateful to Bayard Colyear for his artistic rendering of Figs 1 and 8b. This work was supported by grants from the Lucille P. Markey Charitable Trust and the Chicago Community Trust to D.H. D.H. is a Lucille P. Markey Scholar in Biomedical Sciences and a Searle Scholar (Chicago Community Trust). S.J.A. is a Howard Hughes Medical Institute Predoctoral Fellow.

References

- Lowry, T.H. & Richardson, K.S. (1987). *Mechanism and Theory in Organic Chemistry*. (3rd edn), Harper and Row, New York.
- Benkovic, S.J. & Schray, K.J. (1978). The mechanism of phosphoryl transfer. In *Transition States of Biochemical Processes*. (Gandour, R.D., ed.), pp. 493–527, Plenum, New York.
- Thatcher, G.R.J. & Kluger, R. (1989). Mechanism and catalysis of nucleophilic substitution in phosphate esters. *Adv. Phys. Org. Chem.* **25**, 99–265.
- Khan, S.A. & Kirby, A.J. (1970). Reactivity of phosphate esters. Multiple structure reactivity correlations for the reaction of triesters with nucleophiles. *J. Chem. Soc. B*, 1172–1182.
- Bunton, C.A. & Chaimovich, H. (1965). The acid-catalyzed hydrolysis of pyrophosphoric acid. *Inorg. Chem.* **4**, 1763–1766.
- Miller, D.L. & Westheimer, F.H. (1966). The hydrolysis of γ -phenylpropyl di- and triphosphates. *J. Am. Chem. Soc.* **88**, 1507–1517.
- Miller, D.L. & Ukena, T. (1969). P_1P_1 -diethyl pyrophosphate. *J. Am. Chem. Soc.* **91**, 3050–3053.
- Osterheld, R.K. (1972). Nonenzymic hydrolysis at phosphate tetrahedra. In *Topics in Phosphorus Chemistry*. (Grayson, M. & Griffith, E.J., eds), pp. 103–254, Interscience, New York.
- Halkides, C.J. & Frey, P.A. (1991). The mechanism of hydrolysis of μ -monothio pyrophosphate. *J. Am. Chem. Soc.* **113**, 9843–9848.
- Lightcap, E.S. & Frey, P.A. (1992). Discrete monomeric metaphosphate anion as an intermediate in the hydrolysis of μ -monothio pyrophosphate. *J. Am. Chem. Soc.* **114**, 9750–9755.
- Jencks, W.P. (1987). *Catalysis in Chemistry and Enzymology*. Dover, New York.
- Williams, A. (1992). Effective charge and transition-state structure in solution. *Adv. Phys. Org. Chem.* **27**, 1–55.
- Kirby, A.J. & Varvoglis, A.G. (1968). The reactivity of phosphate esters: reactions of monoesters with nucleophiles. Nucleophilicity independent of basicity in a bimolecular substitution reaction. *J. Chem. Soc. B*, 135–141.
- Kirby, A.J. & Jencks, W.P. (1965). The reactivity of nucleophilic reagents toward the *p*-nitrophenyl phosphate dianion. *J. Am. Chem. Soc.* **87**, 3209–3216.
- Herschlag, D. & Jencks, W.P. (1989). Evidence that metaphosphate monoanion is not an intermediate in solvolysis reactions in aqueous solution. *J. Am. Chem. Soc.* **111**, 7579–7586.
- Pappu, K.M., Gregory, J.D. & Serspersu, E.H. (1994). Substrate activity of Rh(III)ATP with phosphoglycerate kinase and the role of the metal ion in catalysis. *Arch. Biochem. Biophys.* **311**, 503–508.
- Mildvan, A.S. & Fry, D.C. (1987). NMR studies of the mechanism of enzyme action. *Adv. Enzymol.* **59**, 241–313.
- Mildvan, A.S. (1979). The role of metals in enzyme-catalyzed substitutions at each of the phosphorus atoms of ATP. *Adv. Enzymol.* **49**, 103–126.
- Mildvan, A.S. & Grisham, C.M. (1974). The role of divalent cations in the mechanism of enzyme catalyzed phosphoryl and nucleotidyl transfer reactions. *Struct. Bond.* **20**, 1–21.
- Benkovic, S.J. & Schray, K.J. (1973). Chemical basis of biological phosphoryl transfer. In *The Enzymes*. (Boyer, P.D., ed.), pp. 201–238, Academic Press, New York.
- Benkovic, S.J. & Dunikoski, L.K., Jr (1971). An unusual rate enhancement in metal ion catalysis of phosphate transfer. *J. Am.*

- Chem. Soc.* **93**, 1526–1527.
22. Williams, A. & Naylor, R.A. (1971). Evidence for $S_N2(P)$ mechanism in the phosphorylation of alkaline phosphatase by substrates. *J. Chem. Soc. B*, 1973–1979.
 23. Herschlag, D. & Jencks, W.P. (1987). The effect of divalent metal ions on the rate and transition-state structure of phosphoryl-transfer reactions. *J. Am. Chem. Soc.* **109**, 4665–4674.
 24. Herschlag, D. & Jencks, W.P. (1989). Phosphoryl transfer to anionic oxygen nucleophiles. Nature of the transition state and electrostatic repulsion. *J. Am. Chem. Soc.* **111**, 7587–7596.
 25. Jones, J.P., Weiss, P.M. & Cleland, W.W. (1991). Secondary ^{18}O isotope effects for hexokinase-catalyzed phosphoryl transfer from ATP. *Biochemistry* **30**, 3634–3639.
 26. Takeuchi, H., Murata, H. & Harada, I. (1988). Interaction of adenosine 5'-triphosphate with Mg^{2+} : vibrational study of coordination sites by use of ^{18}O -labeled triphosphates. *J. Am. Chem. Soc.* **110**, 392–397.
 27. Di Sabato, G. & Jencks, W.P. (1961). Mechanism and catalysis of reactions of acyl phosphates. II. Hydrolysis. *J. Am. Chem. Soc.* **83**, 4400–4405.
 28. Kirby, A.J. & Varvoglis, A.G. (1967). The reactivity of phosphate esters. Monoester hydrolysis. *J. Am. Chem. Soc.* **89**, 415–423.
 29. Jencks, W.P. (1985). A primer for the Bema Hypothesis. An empirical approach to the characterization of changing transition-state structure. *Chem. Rev.* **85**, 511–527.
 30. Hollfelder, F. & Herschlag, D. (1995). The nature of the transition state for enzyme-catalyzed phosphoryl transfer. Hydrolysis of *o*-arylphosphorothioates by alkaline phosphatase. *Biochemistry* **34**, 12255–12264.
 31. Weiss, P.M. & Cleland, W.W. (1989). Alkaline phosphatase catalyzes the hydrolysis of glucose 6-phosphate via a dissociative mechanism. *J. Am. Chem. Soc.* **111**, 1928–1929.
 32. Hassett, A., Blattler, W. & Knowles, J.R. (1982). Pyruvate kinase: is the mechanism of phospho transfer associative or dissociative? *Biochemistry* **21**, 6335–6340.
 33. Abrahams, J.P., Leslie, A.G.W., Lutter, R. & Walker, J.E. (1994). Structure at 2.8 Å resolution of F1-ATPase from bovine heart mitochondria. *Nature* **370**, 621–628.
 34. Cross, R.L. (1994). Our primary source of ATP. *Nature* **370**, 594–595.
 35. DeBonds, H.L., Rosenblatt, J., Jancarik, J., Jones, H.D., Morgan, D.O. & King, S.-H. (1993). Crystal structure of cyclin-dependent kinase 2. *Nature* **363**, 595–602.
 36. Fisher, A.J., Smith, C.A., Thoden, J.B., Sutoh, K., Holden, H.M. & Rayment, I. (1995). X-ray structures of the myosin motor domain of *Dictyostelium discoideum* complexed with $MgADP \cdot BeF_x$ and $MgADP \cdot AlF_4^-$. *Biochemistry* **34**, 8960–8972.
 37. Frech, M., et al., & Wittinghofer, A. (1994). Role of glutamine-61 in the hydrolysis of GTP by p21^{H-ras}: an experimental and theoretical study. *Biochemistry* **33**, 3237–3244.
 38. Huang, W., et al., & Lindqvist, Y. (1995). Mechanism of an ATP-dependent carboxylase, dethiobiotin synthetase, based on crystallographic studies of complexes with substrates and a reaction intermediate. *Biochemistry* **34**, 10985–10995.
 39. Langen, R., Schweins, T. & Warshel, A. (1992). On the mechanism of guanosine triphosphate hydrolysis in *ras* p21 proteins. *Biochemistry* **31**, 8691–8696.
 40. Milburn, M.V., et al., & Kim, S.-H. (1990). Molecular switch for signal transduction: structural differences between active and inactive forms of protooncogenic *ras* proteins. *Science* **247**, 939–945.
 41. Nassar, N., Horn, G., Herrmann, C., Scherer, A., McCormick, R. & Wittinghofer, A. (1995). The 2.2 Å crystal structure of the Ras-binding domain of the serine/threonine kinase c-Raf1 in complex with Rap1A and a GTP analogue. *Nature* **375**, 554–560.
 42. Pai, E.F., Krengel, U., Petsko, G.A., Goody, R.S., Kabsch, W. & Wittinghofer, A. (1990). Refined crystal structure of the triphosphate conformation of H-ras p21 at 1.35 Å resolution: implications for the mechanism of GTP hydrolysis. *EMBO J.* **9**, 2351–2359.
 43. Payne, M.A., Rao, G.S.J., Harris, B.G. & Cook, P.F. (1995). Acid-base catalytic mechanism and pH dependence of fructose 2,6-bisphosphate activation of the *Ascaris suum* phosphofructokinase. *Biochemistry* **34**, 7781–7787.
 44. Schweins, T., Geyer, M., Scheffzek, K., Warshel, A., Kalbitzer, H.R. & Wittinghofer, A. (1995). Substrate-assisted catalysis as a mechanism for GTP hydrolysis of p21^{H-ras} and other GTP-binding proteins. *Nat. Struct. Biol.* **2**, 36–44.
 45. Sondek, J., Lambright, D.G., Noel, J.P., Hamm, H.E. & Sigler, P.B. (1994). GTPase mechanism of G proteins from the 1.7 Å crystal structure of transducin α -GDP- AlF_4^- . *Nature* **372**, 276–279.
 46. Herschlag, D. & Jencks, W.P. (1990). Catalysis of the hydrolysis of phosphorylated pyridines by $Mg(OH)^+$: a possible model for enzymatic phosphoryl transfer. *Biochemistry* **29**, 5172–5179.
 47. Benner, S.A. & Gerloff, D. (1991). Patterns of divergence in homologous proteins as indicators of secondary and tertiary structure: a prediction of the structure of the catalytic domain of protein kinases. *Adv. Enz. Reg.* **31**, 121–181.
 48. Bossemeyer, D., Engh, R.A., Kinzel, V., Ponstingl, H. & Huber, R. (1993). Phosphotransferase and substrate binding mechanism of the cAMP-dependent protein kinase catalytic subunit from porcine heart as deduced from the 2.0 Å structure of the complex with Mn^{2+} adenylyl imidodiphosphate and inhibitor peptide PKI(5-24). *EMBO J.* **12**, 849–859.
 49. Coleman, D.E., Berghuis, A.M., Lee, E., Linder, M.E., Gilman, A.G. & Sprang, S.R. (1994). Structures of active conformations of $G_{i\alpha 1}$ and the mechanism of GTP hydrolysis. *Science* **265**, 1405–1412.
 50. Goldberg, J., Huang, H., Kwon, Y., Greengard, P., Nairn, A.C. & Kuriyan, J. (1995). Three-dimensional structure of the catalytic subunit of protein serine/threonine phosphatase-1. *Nature* **376**, 745–753.
 51. Morera, S., et al., & Janin, J. (1994). Adenosine 5'-diphosphate binding and the active site of nucleoside diphosphate kinase. *Biochemistry* **33**, 459–467.
 52. Owen, D.J., Noble, M.E.M., Garman, E.F., Papageorgiou, A.C. & Johnson, L.N. (1995). Two structures of the catalytic domain of phosphorylase kinase: an active protein kinase complexed with substrate analogue and product. *Structure* **3**, 467–482.
 53. Yoon, M.-Y. & Cook, P.F. (1987). Chemical mechanism of the adenosine cyclic 3',5'-monophosphate dependent protein kinase from pH studies. *Biochemistry* **26**, 4118–4125.
 54. Levitt, M. (1971). Conformational analysis of proteins. PhD, Cambridge University.
 55. Narlikar, G.J., Gopalakrishnan, V., McConnell, T.S., Usman, N. & Herschlag, D. (1995). Use of binding energy by an RNA enzyme for positioning and substrate destabilization. *Proc. Natl. Acad. Sci. U.S.A.* **92**, 3668–3672.
 56. Herschlag, D.H., Eckstein, F. & Cech, T.R. (1993). The importance of being ribose at the cleavage site in the *Tetrahymena* ribozyme reaction. *Biochemistry* **32**, 8312–8321.
 57. Jencks, W.P. (1975). Binding energy, specificity, and enzymic catalysis: the Circe effect. *Adv. Enzymol.* **43**, 219–410.
 58. Ray, W.J., Jr. & Long, J.W. (1976). Thermodynamics and mechanism of the PO_3 transfer process in the phosphoglucomutase reaction. *Biochemistry* **15**, 3993–4006.
 59. Ray, W.J., Jr., Long, J.W. & Owens, J.D. (1976). An analysis of the substrate-induced rate effect in the phosphoglucomutase system. *Biochemistry* **15**, 4006–4017.
 60. Milburn, R.M., Gautam-Basak, M., Tribolet, R. & Sigel, H. (1985). Comparison of the effectiveness of various metal ions on the promoted dephosphorylation of adenosine 5'-triphosphate (ATP) and uridine 5'-triphosphate (UTP). *J. Am. Chem. Soc.* **107**, 3315–3321.
 61. Amsler, P.W. & Sigel, H. (1976). Comparison of the metal-ion-promoted dephosphorylation of the 5'-triphosphates of adenosine, inosine, guanosine, and cytidine by Mn^{2+} , Ni^{2+} , and Zn^{2+} in binary and ternary complexes. *Eur. J. Biochem.* **63**, 569–581.
 62. Frey, C.M., Banyasz, J.L. & Stuehr, J.E. (1972). Interactions of divalent metal ions with inorganic and nucleoside phosphates. II. Kinetics of magnesium(II) with $HP_2O_6^{4-}$, ATP, CTP, $HP_2O_7^{3-}$, ADP, and CDP. *J. Am. Chem. Soc.* **94**, 9198–9204.
 63. Tetas, M. & Lowenstein, J.M. (1963). The effect of bivalent metal ions on the hydrolysis of adenosine di- and triphosphate. *Biochemistry* **2**, 350–357.
 64. Nanninga, L.B. (1957). Formation constants and hydrolysis at 100° of calcium and magnesium complexes of adenosine tri-, di-, and monophosphate. *J. Phys. Chem.* **61**, 1144–1149.
 65. Lightcap, E.S., Halkides, C.J. & Frey, P.A. (1991). Interactions of metal ions with μ -monothioiopyrophosphate. *Biochemistry* **30**, 10307–10313.
 66. Moffatt, J.G. & Khorana, H.G. (1961). Nucleoside polyphosphates. X. The synthesis and some reactions of nucleoside-5' phosphoromorpholidates and related compounds. Improved methods for the preparation of nucleoside-5' polyphosphates. *J. Am. Chem. Soc.* **83**, 649–658.
 67. Osterheld, R.K. (1958). Kinetics of the aqueous reversion of pyrophosphate. *J. Phys. Chem.* **62**, 1133–1135.
 68. McGilvery, J.D. & Crowther, J.P. (1954). The hydrolysis of the condensed phosphates. *Can. J. Chem.* **32**, 174–185.
 69. Campbell, D.O. & Kilpatrick, M.L. (1954). A kinetic study of the hydrolysis of pyrophosphates. *J. Am. Chem. Soc.* **76**, 893–901.
 70. Taussky, H.H. & Shorr, E. (1953). A microcolorimetric method for the determination of inorganic phosphorus. *J. Biol. Chem.* **202**, 675–685.
 71. Williams, A. (1984). Effective charge and Leffler's index as mechanistic tools for reactions in solution. *Acc. Chem. Res.* **17**, 425–430.

72. Bourne, N. & Williams, A. (1984). Effective charge on oxygen in phosphoryl ($-\text{PO}_3^{2-}$) group transfer from an oxygen donor. *J. Org. Chem.* **49**, 1200–1204.
73. Pecoraro, V.L., Hermes, J.D. & Cleland, W.W. (1984). Stability constants of Mg^{2+} and Cd^{2+} complexes of adenine nucleotides and thionucleotides and rate constants for formation and dissociation of MgATP and MgADP. *Biochemistry* **23**, 5262–5271.
74. Phillips, R.C., George, P. & Rutman, R.J. (1966). Thermodynamic studies of the formation and ionization of the magnesium(II) complexes of ADP and ATP over the pH range 5 to 9. *J. Am. Chem. Soc.* **88**, 2631–2640.
75. Jencks, W.P. & Regenstein, J. (1976). Ionization constants of acids and bases. In *Handbook of Biochemistry and Molecular Biology*. (Fasman, G.D., ed.), pp. 305–351, CRC Press, Cleveland.
76. International Union of Pure and Applied Chemistry, Commission on Equilibrium Data. (1979). *Ionisation Constants of Organic Acids in Aqueous Solution*. Pergamon Press, Oxford.
77. Smith, R.M. & Alberty, R.A. (1956). The apparent stability constants of ionic complexes of various adenosine phosphates with monovalent cations. *J. Phys. Chem.* **60**, 180–184.
78. More O'Ferrall, R.A. (1970). Relationships between *E2* and *E1cB* mechanisms of β -elimination. *J. Chem. Soc. B* 274–277.
79. Jencks, W.P. (1980). When is an intermediate not an intermediate? Enforced mechanisms of general acid-base catalyzed, carbocation, carbanion, and ligand exchange reactions. *Acc. Chem. Res.* **13**, 161–169.
80. Hengge, A.C., Edens, W.A. & Elsing, H. (1994). Transition state structures for phosphoryl-transfer reactions of *p*-nitrophenyl phosphate. *J. Am. Chem. Soc.* **116**, 5045–5049.
81. Horn, H. & Ahlrichs, R. (1990). Energetic measure for the ionic character of bonds. *J. Am. Chem. Soc.* **112**, 2121–2124.
82. Rajca, A., Rice, J.E., Streitwieser, A., Jr. & Schaefer, H.F., III. (1987). Metaphosphate and tris(methylene)metaphosphate ($\text{P}(\text{CH}_2)^{3-}$) anions. Do they have three double bonds to phosphorus? *J. Am. Chem. Soc.* **109**, 4189–4192.

Received: 21 Aug 1995; revisions requested: 6 Sep 1995;
revisions received: 10 Oct 1995. Accepted: 10 Oct 1995.

